



Silentlite® LED Lighting & Virtual Skylite System



**A State-of-the-Art Dimmable MRI Compatible
LED Lighting & Virtual Skylite System Designed
by European EMC Products Limited**

Installations Comprise Of:

- 6, 8, or 12 LED aluminium panels. Bespoke options available upon request.
- Optional 1 - 2 power circuits.
- In the event of power failure specified panels in the system act as a battery back-up.
- Furthermore, clients are provided with the option of adding our decorative panel mood lighting system **Virtual Skylites** to their installation. These can also be fitted as a standalone product against an existing lighting system.
- **Warranty:** 12 months from practical completion.



Specification & Set Up:

- 220/240V 50/60Hz input.
- 40V DC lighting system meets SELV circuit requirements.
- Battery back-up standby capability:
 - 60 minutes before lux level falls below 50 lux.
 - 4 hours before lux level falls below 10 lux.

Batteries require 6 hours to recharge.

** The above quoted figures are for a typical system install with two panels battery backed up.*

- Control box includes input and output RF filtration.
- Silentlite® consumes just 25% of the power of Halogen lighting which reduces energy costs and air conditioning.
- Anticipated annual saving for an MRI chamber: £600.
- High quality lighting – colour rendition index of 85; colour temperature 4100K.
- Each panel fits a standard 600 x 600mm ceiling grid and weighs 2kg.
- 120° beam angle.
- Silentlite® control electronics assures no possibility of strobing.
- MTBF to Mil Std 217F – 30,000hrs at full illumination, 25°C ambient (Ground Benign).
- Silentlite® in kit form contains all the proprietary components necessary for installation. The only additional items required are a double pole switched mains fee and consumables.
- The Silentlite® control box which contains the power supply unit, current control boards, back up batteries and RF Filters mounts on the outside of the Faraday Cage. All connections are filtered, therefore no radio frequency interference is induced, conducted, or radiated into the chamber.



Typical Installation Schematic

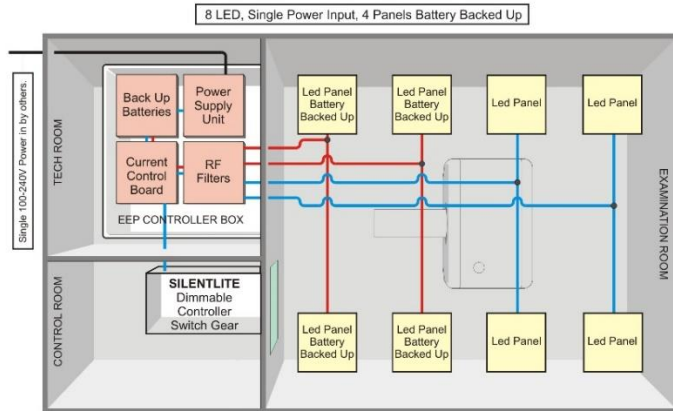

SILENTLITE® carries a Declaration of Conformity covering compliance to the Low Voltage and EMC Directives for use in the medical environment: EN60950-1:2001 and EN60601-1-2:2001.

SILENTLITE®; a unique LED lighting system designed to meet the demands of an MRI Chamber

Utilising the latest long-life dimmable, white, LED lamps, a lifespan of 50,000 hours or more can be achieved with a Silentlite® installation. Providing high quality light at higher efficiencies, our patented lamps are unaffected by the strong magnetic fields created by an MRI scanner, and provide a low interference and reliable alternative to Tungsten Halogen Lighting.

Tungsten halogen had been the preferred method for lighting MRI chambers for many years. With their improved efficiency, lengthier claimed life span, excellent light quality and non-magnetic construction they make the obvious choice. Unfortunately, Tungsten halogen lamps used in MRI examination rooms do not seem to achieve their published lifetimes; Filament stress due to the high magnetic fields is the likely cause of premature failures.

The latest white LED lighting promises high quality light with ultra-long lifetimes. They are non-magnetic and completely unaffected by strong magnetic fields - an irresistible choice for MRI lighting? Regrettably, most commercially available LED lighting systems use switch-mode power control which produces radio frequency interference, which therefore renders them unsuitable for MRI examination room use.

Silentlite® produces virtually no electromagnetic emissions and consumes just 25% of the power of halogen lighting - reducing energy costs by an anticipated £600 for an MRI chamber annually. The LED panels are extremely lightweight, and the assembly is SELV (Safety Extra Low Voltage) for easy installation.

The Silentlite® control box which contains the power supply unit, current control boards, back up batteries and RF filters mounts on the outside of the Faraday Cage. All connections are filtered, therefore no radio frequency interference is induced, conducted or radiated into the chamber.

Silentlite® is also available in Kit Form which contains all the proprietary components required for installation.

- Non-Magnetic Luminaires
- Battery Back-Ups in the Event of Power Failure (if the lights are already on)
- Dimming & Parallel Redundancy
- Generates no RF Interference
- High Reliability & Long Lifespan
- Excellent Colour Rendition
- Adjustable Illumination - 15-300 Lux
- Modular & Upgradeable
- SELV (Safety Extra Low Voltage) Efficient LED Light Engines
- Energy & Maintenance Cost Savings

Virtual Skylites & Wall Panels



SILENTLITE® Virtual Skylites and Virtual Wall Panels are a high-definition image, MRI compatible, decorative LED panel mood lighting system. The LED picture panels are positioned ideally to provide a focal point for the patient and their aim is to assist in creating a more calming and relaxing environment whilst they undergo their scan. The picture ceiling also aids in making the room feel less clinical.

Our Virtual Skylights are not solely for use in MRI rooms. Both ceiling and wall panels can be manufactured for use in a variety of healthcare facilities/areas such as X-Ray Rooms, CT Rooms, Dental Practices, Clinics and Consulting Rooms. What's more, they can be fitted as a standalone product against an existing lighting system or be incorporated into a Silentlite® LED panel lighting installation.

A popular configuration choice is using 2 x 2 LED panels measuring 1.2 x 1.2 metres, or a 3 x 2 measuring 1.2 x 1.8 metres. Panels can either be ceiling mounted within an existing ceiling grid, or wall mounted in a frame.

Images can be chosen from our standard range, or bespoke panels can be created utilising high-definition images supplied by our clients, so long as the copyright is owned.

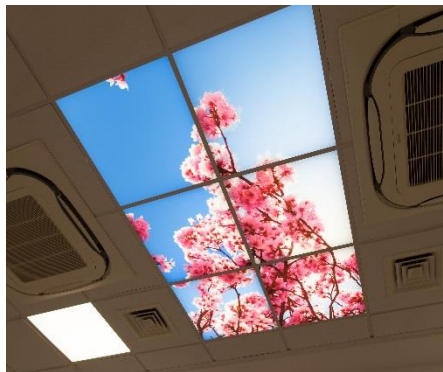



Virtual Skylites in Dental Practices

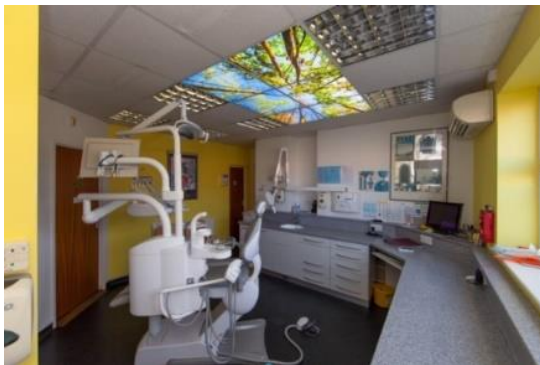

Virtual Skylites & Wall Panels Specification:

- 40V DC lighting system meets SELV circuit requirements.
- Control box includes input and output RF filtration
- Virtual Skylites and Wall Panels consume just 25% of the power of Halogen lighting which reduces energy costs and air conditioning.
- High quality lighting – colour rendition index of 85; colour temperature 4100K.
- Each panel fits a standard 600 x 600mm ceiling grid and weighs 2kg.
- Virtual Skylites and Wall Panels control electronics assures no possibility of strobing.
- Optional 1 – 4 power circuits.
- MTBF to Mil Std 217F – 30,000hrs at full illumination, 25°C ambient (Ground Benign)
- **Warranty:** 12 months from practical completion.

Choose from 1000's of images from our standard range. Alternatively, bespoke panels can be created via high definition images supplied by our clients.

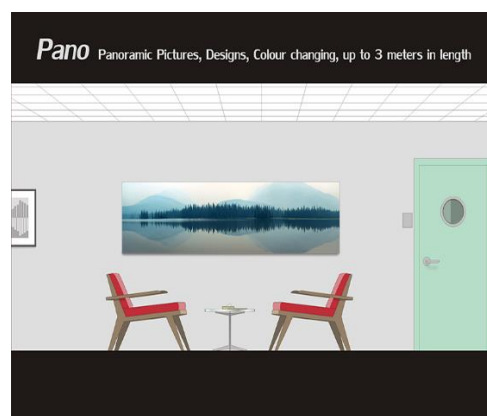
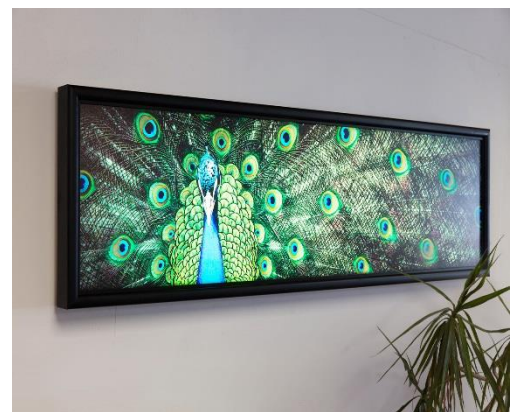

Declaration of Conformity

We, European EMC Products Ltd, declare under our sole responsibility that the product:

Product Name: Silentlite® – MRI Facility Lighting Apparatus

Model Number: SL120

Complies with the requirements and provisions of the Low Voltage Directive 2006/95/EC and the EMC Directive 2004/108/EEC for equipment used in the medical environment (non-life supporting), and carries the CE mark accordingly.

All products covered in this declaration are manufactured in accordance with BS EN ISO 9001:2000 which ensures continued compliance with the LV and EMC Directives.

The product conforms to the following specifications:

Safety: EN60950-1:2001

EMC: EN60601-1-2:2001(A1)

This covers testing to the following standards:

EMISSIONS:

EN55011	CONDUCTED EMISSIONS	CISPR22(B)
EN55011	RADIATED EMISSIONS	CISPR22(B)
EN61000-3-2	HARMONIC CURRENTS	CLASS C
EN61000-3-3	FLICKER	PASS

IMMUNITY:

EN61000-4-3	RADIATED FIELD IMMUNITY	3V/m 80-2500MHz 80%am
EN61000-4-6	CONDUCTED RF IMMUNITY	3Vrms 0.15-80MHz 80%am
EN61000-4-4	ELECTRICAL FAST TRANSIENTS	2kV (power), 1kV (signal)
EN61000-4-2	ELECTROSTATIC DISCHARGE	2, 4, 6, 8kV
EN61000-4-11	VOLTAGE DIPS AND INTERRUPTIONS	>95% reduction 5 seconds
EN61000-4-8	POWER FREQUENCY MAGNETIC FIELD	50/60Hz 3A/m

Name of authorised signatory:	
Signature of authorised signatory:	
Position of authorised signatory:	
Date:	
Place:	

European EMC Products Limited – Turnkey MRI Solutions

European EMC Products are a world leader in the design, manufacture and installation of RF Shielded Rooms, Quench Pipes and Magnetic Field Shielding for MRI scanners. We have been working with MRI scanner manufacturers and main contractors for many years, therefore we are ideally placed for all MRI Shielding requirements.



MRI Shielded Rooms

European EMC Products provide Radio Frequency (RF) shielding for MRI rooms in the form of a Faraday Cage. These Faraday Cages cover the requirements of all the major MRI scanner manufacturers such as Siemens, Philips Medical, General Electric and Toshiba.

As part of our turnkey offerings we also manufacture and supply RF Shielded Doors, Windows and Waveguide Vents. In addition to the above, and as a pre-cursor to building the room, we can also undertake optional site vibration and magnetic field fluctuation surveys to ensure the ground conditions meet with the manufacturer's specified limits.

MRI Quench Pipes

A Quench is a sudden loss of superconductivity in the wire of the magnet. The stored magnetic energy turns into heat, causing the liquid helium to boil off very rapidly. Many thousands of cubic metres of helium gas can be released in a few minutes, and the vent pipe has to be able to carry this flow safely.

We offer a bespoke Quench Pipe design, manufacture and installation to approved industry and safety standards, and follow strict procedures whilst undertaking materials selection.

Magnetic Field Shielding

Magnetic fields are generated by permanent magnets, electromagnets, electric motors, electrical distribution systems and MRI Scanners. When these magnetic fields need to be contained or controlled, European EMC Products can design and install specialist shielding.

Prior to commencing the full design and installation of the physical magnetic field shielding, EEP can also plot the magnetic lines of force to verify where the magnetic field strength is located. By understanding the field shape, we are able to optimise the shield's design.



About Us

Established in 1996, European EMC Products (EEP) are an established British company whose experience and understanding of the science of shielding makes it an ideal partner in whom you can place your trust with confidence. The purpose of installing EEP shielding systems is to protect people and equipment against the threats posed by electromagnetic and radio frequency (RF) interference, radiation, magnetic fields and electromagnetic pulses. Our diverse range of turnkey products and services, including design, project management, testing and consultancy are delivered across multiple sectors to an international client base.

Quality

European EMC Products Limited are registered to BS EN ISO 9001:2015, Certificate Number FS38901. Registered Scope: The design, assembly, installation, servicing and testing of RF Shielded Structures and equipment including EMI Shielding, Blast Doors, Gas Tight Doors and specialised mobile Electromagnetic Pulse Protection (EMPP) containers.

Radio Frequency, Magnetic Shielding and Quench systems for MRI (Magnetic Resonance Imaging) scanners.

The design, assembly and installation of Ionising Radiation Protection facilities.

The design, manufacture and installation of LED lighting systems for medical applications.

EEP Filters Limited are registered to BS EN ISO 9001:2015, Certificate Number FS38901.

Registered Scope: The design, manufacture, management of installation and testing of high performance EMC and EMP Power and Data Line Filters.

Disclaimer

NB: All the information provided within this datasheet is for reference only. Product specifications are subject to change without notice.